

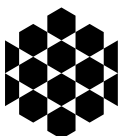

# Parking Standards



An Agency within the Department of the  
**Environment**  
[www.doeni.gov.uk](http://www.doeni.gov.uk)



INVESTOR IN PEOPLE

# *Contents*

|                                                        | <b>Page No.</b> |
|--------------------------------------------------------|-----------------|
| <b>Introduction</b>                                    | 1               |
| <b>General Considerations</b>                          | 1-2             |
| <b>Cycle Parking</b>                                   | 2-3             |
| <b>Motorcycle Parking</b>                              | 3               |
| <b>Interpretation</b>                                  | 3               |
| <b>Parking Standards - Non-Residential Development</b> | 4-12            |
| <br><b>Annexes</b>                                     |                 |
| Annex A    Residential Parking Standards               | 13-15           |
| Annex B    Cycle Parking Design Details                | 16-21           |

## Introduction

1. This document sets out the parking standards that the Department will have regard to in assessing proposals for new development. It includes parking standards for residential development previously published in 'Creating Places – Achieving Quality in Residential Developments'.
2. The standards comprise Supplementary Planning Guidance and should be read in conjunction with the relevant policies contained in Planning Policy Statements or the development plan.
3. The principle objective of the parking standards is to ensure that, in assessing development proposals, appropriate consideration is given to the accommodation of vehicles attracted to the site within the context of wider government policy aimed at promoting modal shift to more sustainable forms of transport.
4. The precise amount of car parking will be determined according to the specific characteristics of the development and its location having regard to these standards or any reduction provided for in an area of parking restraint designated in a development plan. Proposals should not prejudice road safety or significantly inconvenience the flow of traffic.
5. Developers are advised to consult the relevant development plans to ascertain whether specific parking limitations apply to their proposed development location.

## General Considerations

6. In assessing the parking provision in association with development the Department will normally expect developers to provide an access to the site in accordance with the current standards<sup>1</sup>. Where appropriate, developers will be required to demonstrate there is adequate provision of space within the site, for parking, manoeuvring, loading and unloading to fulfil the operational requirements of the proposed development.
7. Where developments incorporate more than one land use which are functioning simultaneously, e.g. a warehouse containing a large office or a public house containing a restaurant, the combined figures applicable to both uses will apply. Conversely, in multi-purpose development where it can be shown that separate uses operate at different times of the day greater flexibility will be applied.
8. Floor areas quoted in the guidelines relate to Gross Floor Area unless otherwise stated.

---

<sup>1</sup> Development Control Advice Note 15, 1999 2<sup>nd</sup> Edition Vehicular Access Standards.

9. The term 'one space' used in the standards refers to standing area only and the recommended **minimum** dimensions for a car space are 4.8 metres by 2.4 metres. The term 'commercial vehicle space' used in the standards refers to the standing area required for the general type of commercial vehicle which would normally serve the particular development.
10. The following are standard space requirements of some typical vehicles. These may be used as basic minimum reference values but different layouts such as parallel, herringbone and in-line, have slightly different overall space requirements and detailed layout of parking spaces will be site specific.

|                      |                          |
|----------------------|--------------------------|
| Car                  | 2.4 metres x 4.8 metres  |
| Light Vans           | 2.4 metres x 5.5 metres  |
| Rigid Vehicles       | 3.5 metres x 14.0 metres |
| Articulated Vehicles | 3.5 metres x 18.5 metres |
| Coaches (60 seats)   | 3.5 metres x 14.0 metres |

These dimensions refer to standing space only and do not take account of access, manoeuvring space or space required for loading/unloading.

11. Operational parking space for commercial and service vehicles will depend on the type attracted to a development and should provide for manoeuvring space to enable vehicles to exit the site in forward gear.
12. Best practice on the number, size and layout of parking spaces reserved for people with disabilities and general guidance on the provision of appropriate related facilities is set out in the Department's guide 'Access for All'.
13. The Department will, on request or as necessary, provide advice on the parking requirement for developments not covered by these standards taking into account the number and size of vehicles likely to use the proposed development at any one time and wider Government policy on transportation.

## Cycle Parking

14. The promotion of cycling as a travel opportunity is part of the drive to promote alternatives to the private car and encourage more sustainable means of travel. One step in this process is to improve the provision, safety, convenience and general environment for cycling by ensuring that the needs of cyclists are fully taken into account in the development process. To help promote cycle use the amount of good quality cycle parking needs to be increased. It is important therefore that secure cycle parking is provided as an integral part of new development.
15. Cycle theft is a major problem and concerns most cyclists. The provision of carefully planned, secure parking facilities can help to reduce this concern

and may also help promote the use of cycle routes. A beneficial effect of providing designated cycle parking areas may be a reduction in haphazard chaining of bicycles to railings, pipes and lighting columns, thus removing clutter and inconvenience to pedestrians and frontages.

16. Where the Department has determined that secure cycle parking facilities should be provided the precise amount will be assessed against the published standards. Full secure, weather protected parking will normally be required for employee cycle parking. Weather protection will also be required for visitor parking where space for ten or more cycles is provided or in cases where medium to long-term cycle parking is required, for instance at public transport interchanges.

## **Motorcycle Parking**

17. Parking provision for motorcycles will be assessed on demand. The number of motorcycles in use in Northern Ireland is approximately 2% of the total number of cars. Where provided or required the location of motorcycle bays within a development should take account of the requirements of users and recognise that they are vulnerable in tight or enclosed space.
18. Motorcycle theft is also a problem that concerns most riders. The provision of carefully planned, secure parking facilities which provide for natural surveillance can help to reduce this concern. Additional security can be afforded through the provision of security bollards or inground motorcycle clamps to which motorcycles can be chained. Purpose built security systems are also available which clamp the front wheel of a motorcycle and include combined storage facilities for clothes and accessories.

## **Interpretation**

19. For the purpose of interpreting the attached standards: -
  - a) Gross floor space shall be calculated by way of internal measurement to the inner face of the exterior wall and shall include any mall, covered entrance lobby, enclosed circulation space, staff accommodation and other ancillary space; and
  - b) Gross retail floorspace is floorspace used for selling goods by retail and includes associated storage space but excludes any mall, covered entrance lobby, enclosed circulation space, staff accommodation and any other ancillary space.
  - c) Net retail floorspace is the area for the sale and display of goods, check-out, counters, packing zones, circulation space from check-outs to exit lobby, fitting rooms and information areas. Net retail floorspace shall be calculated by way of internal measurement to the inner face of the wall.

## Parking Standards - Non-residential

| Use Class <sup>2</sup>                                             | Description                                                                                                                                     | Non-Operational Parking Space     | Operational Parking Space                                   | Cycle Parking Standard                                                          |
|--------------------------------------------------------------------|-------------------------------------------------------------------------------------------------------------------------------------------------|-----------------------------------|-------------------------------------------------------------|---------------------------------------------------------------------------------|
| <b>Class A1: Shops</b>                                             | Food retail                                                                                                                                     | 1 space per 14 m <sup>2</sup> GFA | 1 lorry space per 750 m <sup>2</sup> of GFA                 | Minimum of 2 per unit or 1 per 500 m <sup>2</sup> GFA which ever is the greater |
|                                                                    | Non food retail                                                                                                                                 | 1 space per 20 m <sup>2</sup> GFA | 1 lorry space per 750 m <sup>2</sup> of GFA                 | Minimum of 2 per unit or 1 per 500 m <sup>2</sup> GFA which ever is the greater |
| <b>Class A2: Financial &amp; Professional &amp; Other Services</b> | Offices and services appropriate to provision in a shopping area where these are provided for the benefit of the visiting members of the public | 1 space per 20 m <sup>2</sup> GFA | 1 space per 3000 m <sup>2</sup> GFA for commercial vehicles | Minimum of 2 per unit                                                           |

<sup>2</sup> Use Class as defined in the Planning (Use Classes) Order (Northern Ireland) 2004.

|                                                                    |                                |                                                                                                                                                                                                                                                                                          |                                                                                                              |                                                                                  |
|--------------------------------------------------------------------|--------------------------------|------------------------------------------------------------------------------------------------------------------------------------------------------------------------------------------------------------------------------------------------------------------------------------------|--------------------------------------------------------------------------------------------------------------|----------------------------------------------------------------------------------|
| <b>Class B1: Business</b>                                          | Class B1 Offices               | 1 space per 20 m <sup>2</sup> GFA up to 500m <sup>2</sup><br>1 space per 30 m <sup>2</sup> GFA above 500 m <sup>2</sup><br>+ 10% of staff parking for visitors                                                                                                                           | 1 space per 930 m <sup>2</sup> GFA<br>1 commercial vehicle space per 3000 m <sup>2</sup>                     | Minimum of 2 per unit or 1 per 20 staff whichever is the greater                 |
|                                                                    | Call centres                   | 1 space per 3 staff + 10% of staff parking for visitors                                                                                                                                                                                                                                  | 1 space per 930 m <sup>2</sup> GFA<br>1 commercial vehicle space per 3000 m <sup>2</sup>                     | Minimum of 2 per unit or 1 per 20 staff whichever is the greater                 |
| <b>Class B2: Light Industrial and Class B3: General Industrial</b> | <250 m <sup>2</sup> GFA        | 1 space per 25 m <sup>2</sup> GFA                                                                                                                                                                                                                                                        | 1 space for commercial vehicles                                                                              | Minimum of 2 per unit                                                            |
|                                                                    | >250 m <sup>2</sup> GFA        | as <250 m <sup>2</sup> with additional 1 space per 50 m <sup>2</sup> GFA for GFA exceeding 250 m <sup>2</sup><br><br>For some units parking will be assessed on individual merits having regard to the number of workers, operating patterns, location and proximity to public transport | A minimum of 1 space or 1 space per 750 m <sup>2</sup> GFA for commercial vehicles, whichever is the greater | Minimum of 2 per unit or 1 per 500 m <sup>2</sup> GFA, whichever is the greater  |
| <b>Class B4: Storage or Distribution</b>                           | Storage or Distribution Centre | 1 space per 250 m <sup>2</sup> GFA                                                                                                                                                                                                                                                       | 1 lorry space per 250 m <sup>2</sup> GFA                                                                     | Minimum of 2 per unit or 1 per 1000 m <sup>2</sup> GFA, whichever is the greater |

|                                           |                                                                                                                           |                                                                                                                                                                                                                     |                                                                                                                                     |                       |
|-------------------------------------------|---------------------------------------------------------------------------------------------------------------------------|---------------------------------------------------------------------------------------------------------------------------------------------------------------------------------------------------------------------|-------------------------------------------------------------------------------------------------------------------------------------|-----------------------|
| <b>Class C2: Guest Houses</b>             | Boarding or guest house or as a hostel where, in each case, no significant element of care is provided                    | 1 space per bedroom, plus restaurant, function room, conference and bar at 1 space per 5 m <sup>2</sup> GFA. Resident staff at 1 space per 3 staff on duty                                                          | Not required                                                                                                                        | Minimum of 2 per unit |
| <b>Class C3: Residential Institutions</b> | Hospital or Nursing Home                                                                                                  | 1 space per Doctor or Consultant<br>1 space per 3 Nursing and Ancillary Staff<br>1 space per 3 beds<br>4 spaces per outpatient consulting room                                                                      | Operational Parking Space for ambulances and service lorries must be provided and will depend on the type and needs of the hospital | 1 per 10 staff        |
|                                           | Residential School, College or Training Centre<br>Sheltered Accommodation for the elderly and/or people with disabilities | 1 space per 3 Nursing and Ancillary Staff<br>0.25-0.5 spaces per bed, greater where particular parking difficulty experienced<br>Where no communal living standards are involved normal residential standards apply | Minimum of 1 lorry / ambulance space                                                                                                | 1 per 10 staff        |

|                                                      |                                                               |                                                                                                                                                      |                                                                                                                                                                                                          |                       |
|------------------------------------------------------|---------------------------------------------------------------|------------------------------------------------------------------------------------------------------------------------------------------------------|----------------------------------------------------------------------------------------------------------------------------------------------------------------------------------------------------------|-----------------------|
| <b>Class D1:<br/>Community and<br/>Cultural Uses</b> | Nursery schools<br>Day nurseries<br>Pre school play groups    | 1 space per 3 staff<br>1 space per 10 children                                                                                                       | 1 Lay-by or turning space as appropriate                                                                                                                                                                 | Minimum of 2 per unit |
|                                                      | Primary Schools                                               | 1 space per teaching staff<br>1 space per 2 ancillary staff<br>One half of total staff provision for visitors                                        | Facilities are required for buses and cars to pick up and set down using either coach space, manoeuvring space or a turning area, all without engaging reverse gear                                      | 1 per 10 students     |
|                                                      | Secondary Schools                                             | 1 space per teaching staff<br>1 space per 2 ancillary staff<br>1 space per 10 pupils over age 17<br>One third of total staff provision for visitors  | Ideally an internal one way system should be provided with associated lay-bye to allow setting down and picking up of pupils by both bus and car                                                         |                       |
|                                                      | Further Education                                             | 1 space per teaching staff<br>1 space per 2 ancillary staff<br>1 space per 4 students over age 17<br>One third of total staff provision for visitors | Space can be provided using reinforced playgrounds and driveways<br><br>A minimum provision for bus spaces will be required with additional provision depending on the needs of the educational facility |                       |
| Libraries<br>Art Galleries<br>Museums                | 1 space per 3 staff plus<br>1 space per 30 m <sup>2</sup> GFA | 1 mobile library parking space                                                                                                                       | Minimum of 10 per unit                                                                                                                                                                                   |                       |

|                                                                         |                                                                                                                                                                                                           |                                                                                                                                                                                                                                  |                                                                                                                                                           |                                                                                                                                                            |
|-------------------------------------------------------------------------|-----------------------------------------------------------------------------------------------------------------------------------------------------------------------------------------------------------|----------------------------------------------------------------------------------------------------------------------------------------------------------------------------------------------------------------------------------|-----------------------------------------------------------------------------------------------------------------------------------------------------------|------------------------------------------------------------------------------------------------------------------------------------------------------------|
| <p><b>Class D1:<br/>Community and Cultural Uses<br/>(continued)</b></p> | <p>Health Centres<br/>Doctors' Surgeries<br/>Day Clinics<br/>Dentists Surgeries<br/>Veterinary Surgeries</p>                                                                                              | <p>1 space per Doctor, Dentist or Vet.<br/>1 space per 2 other staff.<br/>4 spaces per consulting or treatment room.<br/>1 ambulance space per Health Centre (minimum)</p>                                                       | <p>Veterinary Surgeries must provide adequate turning and manoeuvring space for larger vehicles with trailers where large animal practice is involved</p> | <p>Minimum of 2 per unit</p>                                                                                                                               |
| <p><b>Class D2:<br/>Assembly and Leisure</b></p>                        | <p>Theatres, Cinemas, Concert Halls, Dance Halls and Bingo Halls</p>                                                                                                                                      | <p>1 space per 3 seats</p>                                                                                                                                                                                                       |                                                                                                                                                           | <p>Minimum of 10 per unit</p>                                                                                                                              |
| <p><b>No Specific Class<br/>'Sui Generis'</b></p>                       | <p>Churches and Church Halls<br/>Indoor / outdoor stadia including rugby, football, soccer, gaelic football, skating etc.<br/>Soccer, Hockey, Rugby, Cricket etc Pitches<br/>Sports / Leisure Centres</p> | <p>1 space per 3 seats<br/>1 space per 3 staff<br/>1 space per 3 players / competitors<br/>1 space per 3 spectators<br/>1 space per 3 players<br/>1 space per 3 staff<br/>1 space per 3 players<br/>1 space per 3 spectators</p> | <p>Churches shall have a minimum of 1 coach space<br/>1 coach space per 500 spectators<br/>1 coach space per 4 pitches</p>                                | <p>Minimum of 10 per unit<br/>Minimum of 10 per unit or 1 per 50 seats, whichever is the greater<br/>Minimum of 2 per pitch<br/>Minimum of 10 per unit</p> |

|                                    |                            |                                                                                                                                                             |                                                                                             |                            |
|------------------------------------|----------------------------|-------------------------------------------------------------------------------------------------------------------------------------------------------------|---------------------------------------------------------------------------------------------|----------------------------|
| <b>Sui Generis<br/>(continued)</b> | Swimming Pool              | 1 space per 3 Staff<br>Patrons = 1 space per<br>5m <sup>2</sup> per pool / rink<br>Spectators = 1 space per<br>3 seats                                      | 1 coach space per 500<br>Spectators                                                         | Minimum of 10 per<br>unit  |
|                                    | Golf Courses               | 1 space per 3 Staff<br>4 spaces per hole for<br>players<br>Bar and restaurant to be<br>assessed separately<br>1½ spaces per bay for a<br>golf driving range |                                                                                             | Minimum of 5 per<br>course |
|                                    | Marinas                    | 1 space per 3 Staff<br>Boat users = 1 space per<br>berth<br>1 trailer space per 10<br>berths                                                                |                                                                                             | Minimum of 5 per unit      |
|                                    | Caravan / Camping<br>Sites | 1 space per 3 Staff<br>(adjacent to site office)<br>1 space per 10 pitches<br>(adjacent to site office)<br>1 space per pitch                                |                                                                                             |                            |
|                                    | Public Open Space          | 4 spaces per hectare                                                                                                                                        |                                                                                             |                            |
|                                    | Taxi Offices               | 1 space per 20 m <sup>2</sup><br>GFA. Depending on the<br>scale and character of<br>the proposal additional<br>parking facilities may be<br>required        | 1 space per 930 m <sup>2</sup><br>1 commercial vehicle space<br>per 3000 m <sup>2</sup> GFA |                            |
|                                    |                            |                                                                                                                                                             |                                                                                             |                            |
|                                    |                            |                                                                                                                                                             |                                                                                             |                            |
|                                    |                            |                                                                                                                                                             |                                                                                             |                            |
|                                    |                            |                                                                                                                                                             |                                                                                             |                            |

|                                    |                                                                         |                                                                                                                                                                        |                                                          |                                       |
|------------------------------------|-------------------------------------------------------------------------|------------------------------------------------------------------------------------------------------------------------------------------------------------------------|----------------------------------------------------------|---------------------------------------|
| <b>Sui Generis<br/>(continued)</b> | Hotels                                                                  | 1 space per bedroom plus restaurant, functionroom, conference and bar at 1 space per 5 m <sup>2</sup> GFA. Resident staff at 1 space per 3 staff on duty               | Minimum of 1 lorry space and manoeuvring space for coach | Minimum of 2 per unit + 1 per 30 beds |
|                                    | Bars                                                                    |                                                                                                                                                                        |                                                          |                                       |
|                                    | Outside development limit                                               | 1 space per 3 m <sup>2</sup> NFA                                                                                                                                       | 1 lorry space when >500 m <sup>2</sup> GFA               | Minimum of 5 per unit                 |
|                                    | Inside development limit                                                | 1 space per 5 m <sup>2</sup> NFA                                                                                                                                       | 1 lorry space when >500 m <sup>2</sup> GFA               |                                       |
|                                    | Restaurants                                                             |                                                                                                                                                                        |                                                          |                                       |
|                                    | Outside development limit                                               | 1 space per 3 m <sup>2</sup> NFA                                                                                                                                       | 1 lorry space when >500 m <sup>2</sup> NFA               | Minimum of 2 per unit                 |
|                                    | Inside development limit                                                | 1 space per 5 m <sup>2</sup> NFA                                                                                                                                       | 1 lorry space when >500 m <sup>2</sup> GFA               |                                       |
|                                    | Roadside restaurant or service restaurant outside the development limit | A minimum of 6 No easily accessible HGV, and 2 No car with caravan spaces plus minimum car parking spaces at 1 space per 3 m <sup>2</sup> NFA plus 1 space per 3 staff | Not required                                             | Minimum of 2 per unit                 |
|                                    | Targeting mixed use of lorries and cars                                 |                                                                                                                                                                        |                                                          |                                       |

|                                    |                                                                                                                                                                                                                                            |                                                                                                                                                                                                                           |                       |
|------------------------------------|--------------------------------------------------------------------------------------------------------------------------------------------------------------------------------------------------------------------------------------------|---------------------------------------------------------------------------------------------------------------------------------------------------------------------------------------------------------------------------|-----------------------|
| <b>Sui Generis<br/>(continued)</b> | Hot food take away.<br>Street frontage infill                                                                                                                                                                                              | 1 space per 3 m <sup>2</sup> NFA and<br>1 space per 3 staff                                                                                                                                                               | Minimum of 2 per unit |
|                                    | Drive through / take<br>away restaurant                                                                                                                                                                                                    | 1 space per 3 m <sup>2</sup> NFA and<br>1 space per 3 staff<br>Minimum length of drive<br>through queue provision<br>should be sufficient for 15<br>cars without interference<br>with other parking or the<br>public road | Minimum of 2 per unit |
|                                    | Transport Café<br>Outside development<br>limit                                                                                                                                                                                             | 1 car parking space per 3<br>staff.<br>1 lorry space per 3 m <sup>2</sup> net<br>floor area                                                                                                                               | Minimum of 2 per unit |
|                                    | Car Showrooms                                                                                                                                                                                                                              | Offices: 1 space per 30 m <sup>2</sup><br>GFA<br>Sales: 1 space per 100 m <sup>2</sup><br>of internal and external<br>sales area                                                                                          | Minimum of 2 per unit |
| Petrol Filling Station             | 1 space per pump<br>position, plus 1 waiting<br>space per pump position<br>not impeding entry or<br>exit from the site or any<br>other site facility, plus<br>appropriately located<br>parking for retail shop as<br>per shopping standard | Space for discharging petrol<br>tanker.<br>Retail as per shopping<br>standard.                                                                                                                                            | Minimum of 2 per unit |

|                                    |                              |                                                                                                                                                                                                                |                          |  |
|------------------------------------|------------------------------|----------------------------------------------------------------------------------------------------------------------------------------------------------------------------------------------------------------|--------------------------|--|
| <b>Sui Generis<br/>(continued)</b> | Garages                      | Add together the number of spaces required for each category, e.g. repair and servicing garages, showrooms, petrol filling station and retail, etc.                                                            | Minimum 1 lorry space    |  |
|                                    | Repair and servicing Garages | Spare parts store - 1 space per 25 m <sup>2</sup> GFA if a main Distributor<br><br>Workshop - 4 spaces per bay or 2 lorry spaces plus 1 car space if a lorry repair shop (the service bay counts as one space) |                          |  |
|                                    | Car Wash                     | 5 spaces for waiting not impeding entry or exit from the site or any other on site facility                                                                                                                    |                          |  |
|                                    | Tyre and Exhaust Centre      | 4 spaces per repair bay (1 repair bay counts as 1 space)<br>2 lorry spaces per lorry repair bay<br>1 space per 3 staff                                                                                         | Minimum of 1 lorry space |  |

# Annex A: Residential Parking Standards

## Car Parking

- A1 The following tables (Tables 7 & 8 from the design guide 'Creating Places') set out the car parking provision required for residents and callers in developments on green-field sites or in low-density areas. Lesser provision may be acceptable in inner urban locations and other high-density areas. In special circumstances, in some inner urban locations, 'car-free' developments may be considered appropriate - where it can be demonstrated that households will not own a car or will keep it elsewhere. Further guidance on reduced parking provision is also provided in Development Control Advice Note 8 Housing in Existing Urban Areas.
- A2 The tables take account of the sizes and types of dwelling to be provided, and the proportions of spaces to be provided within house curtilages and / or in communal grouped parking spaces.
- A3 The provision required beyond house curtilages should be located in off-street communal parking areas or parking bays contiguous with carriageways.
- A4 A carriageway width of 5.5m is intended to allow for parking by casual callers, and these spaces may be counted towards the total provision required provided:
- they are clearly indicated on the submitted layout plan; and
  - they do not obstruct entrances to driveways or block access along the carriageway.
- A5 Where in-curtilage parking is provided and driveways, by virtue of their length, can accommodate 2 or more cars parking end to end, no more than 2 of these spaces will be counted towards the in-curtilage provision.
- A6 Garages will only be counted towards the in-curtilage provision, where they are large enough to both accommodate cars and make provision for general storage, or alternatively, provision for general storage can be made elsewhere within the curtilage.
- A7 Each part of the layout should be self-sufficient with regard to its parking provision. For larger developments it will therefore be necessary to consider each part of the development separately to arrive at an appropriate total requirement.
- A8 Table 7 sets out the parking requirements for apartments and terraced houses that only have communal provision. Table 8 sets out the requirements for houses having one or more parking spaces within the curtilage. The total requirements given include spaces for residents, visitors and other callers.

**Table 7 Total number of parking spaces per dwelling required for apartments and houses that have only communal parking provision.**

|                       | Dwelling size (bedrooms) | Total no. of parking spaces required per dwelling (unassigned spaces) | Total no. of parking spaces required per dwelling (assigned spaces)* |
|-----------------------|--------------------------|-----------------------------------------------------------------------|----------------------------------------------------------------------|
| <b>Apartments</b>     | Bedsit and 1 bed         | 1.25                                                                  | 1.5                                                                  |
|                       | 2 bed                    | 1.5                                                                   | 1.75                                                                 |
|                       | 3 bed                    | 1.75                                                                  | 2.0                                                                  |
| <b>Terrace houses</b> | 1 and 2 bed              | 1.5                                                                   | 1.75                                                                 |
|                       | 3 bed                    | 1.75                                                                  | 2.0                                                                  |

\*Communal parking areas with assigned spaces will not be adopted for future maintenance by the Road Service.

**Table 8 Total number of parking spaces per dwelling required for houses that have in-curtilage parking provision.**

|                                            | Dwelling size (bedrooms) | Total no. of parking spaces required per dwelling |      |      |      |
|--------------------------------------------|--------------------------|---------------------------------------------------|------|------|------|
|                                            |                          | 1                                                 | 2    | 3    | 4    |
| <b>No. of in-curtilage spaces provided</b> |                          |                                                   |      |      |      |
| <b>Terrace houses</b>                      | 1 bed                    | 1.75                                              | 2.25 |      |      |
|                                            | 2 and 3 bed              | 2                                                 | 2.25 |      |      |
| <b>Semi-detached houses</b>                | 3 bed                    | 2.25                                              | 2.5  | 3.25 | 4.25 |
|                                            | 4 bed                    | 2.5                                               | 2.75 | 3.5  | 4.25 |
| <b>Detached houses</b>                     | 3 bed                    | 2.5                                               | 2.75 | 3.5  | 4.25 |
|                                            | 4 bed                    | 2.75                                              | 3    | 3.75 | 4.5  |
|                                            | 5 bed                    | 3                                                 | 3.25 | 3.75 | 4.5  |

## Cycle Parking

- A9 The design guide 'Creating Places' states that sufficient space should be provided for bicycle parking within dwellings, garages or outside. Communal bicycle stands should normally be provided in association with apartment developments.
- A10 Communal bicycle stands needed for apartments should be located so that they can readily be seen from front windows and entrances to provide informal surveillance. They should be well-lit after dark to enhance personal and bicycle security.
- A11 Provision should normally be made for bicycles to be supported independently of each other. To promote security, the parking facility should make it possible for the frame of the bicycle and, if possible, both wheels to be locked to the fixture.
- A12 A recommended bicycle parking facility is the 'Sheffield Stand'. Other facilities may also be acceptable and the advice of the Department for Regional Development's Roads Service should be sought.

# Annex B: Cycle Parking Design Details

## Cycle Parking General Requirements

B1 Cycle parking facilities should be:-

- Conveniently located;
- Secure;
- Easy to use;
- Adequately lit;
- Well signed and; preferably,
- Sheltered.

## Cycle Parking Design

B2 Ideally a cycle parking facility should allow for the frame and both wheels to be locked to the fixture. Cycle stands which only grip the cycle by a wheel (these include concrete slots) are not recommended as they offer only limited security and can result in damage to wheel rims. The accepted types of cycle parking facility are: -

1. Sheffield style.
2. Rail or Guard rail.
3. Wall bracket.
4. Cycle locker.

B3 Other types or innovative designs will be considered on their merits, however, types, which solely support wheels, are only considered suitable within secure buildings.

B4 When designing parking facilities the space required for a parked cycle should be taken as 2,000mm (length) by 600mm (width).

B5 It is recommended that parking facilities should be located as close as possible to the entrance of the establishment they are intended to serve in order that convenience and security may be maximised. Where possible they should be placed so that they may be overlooked by occupiers of the buildings or be in clear view of pedestrians.

B6 Stands placed in dark recesses or at the rear of car parks will not be accepted as these will not be attractive in terms of security and are therefore unlikely to be used.

B7 Cycle stands should be placed carefully in relation to their surroundings. The appearance of cycle stands may be enhanced by incorporating them into wider environmental improvement schemes. Care should be taken to ensure that any stand provided does not obstruct pedestrians or incorporate dangerous projections.

B8 Designs should aim to be:-

- Secure;
- Vandal-proof;
- Well lit;
- Easy to use, and
- Accessible.

B9 Sheffield stands and wall loops are recommended, preferably situated as close to the destination point as possible, in well signed small groups within appropriately illuminated areas.

**Figure 1: Sheffield Stand**

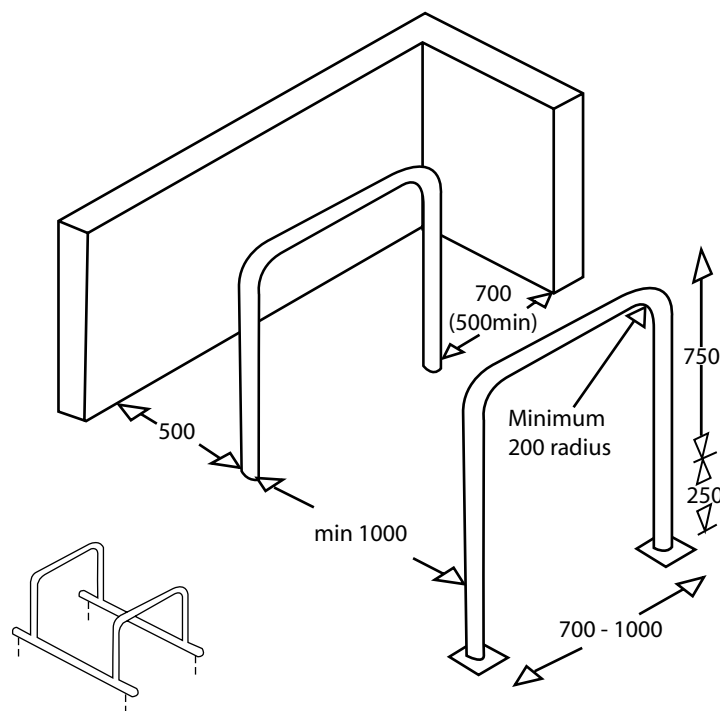

Note: All dimensions are in millimetres

## Sheffield Stand

B10 A typical Sheffield Stand layout is shown on Figure 1. The stand provides good support to the cycle and allows the cyclist to secure both the frame and wheels without risk of damage. Stands should be 750mm high and a minimum of 700mm long. A desirable minimum distance of 1,000mm should be provided between stands to accommodate two cycles per stand. Stand ends should either be embedded in concrete, bolted to the ground or welded to parallel bars at ground level to form a 'toast rack' system. Adequate space should be provided at either end of the stand to enable cycles to be easily removed. (Desirable size 700, minimum 500mm).

B11 At schools, leisure facilities or other similar locations where children may attend, an extra horizontal bar should be provided 500mm above ground level to provide support for children's cycles.

**Figure 2: Wall Bars**

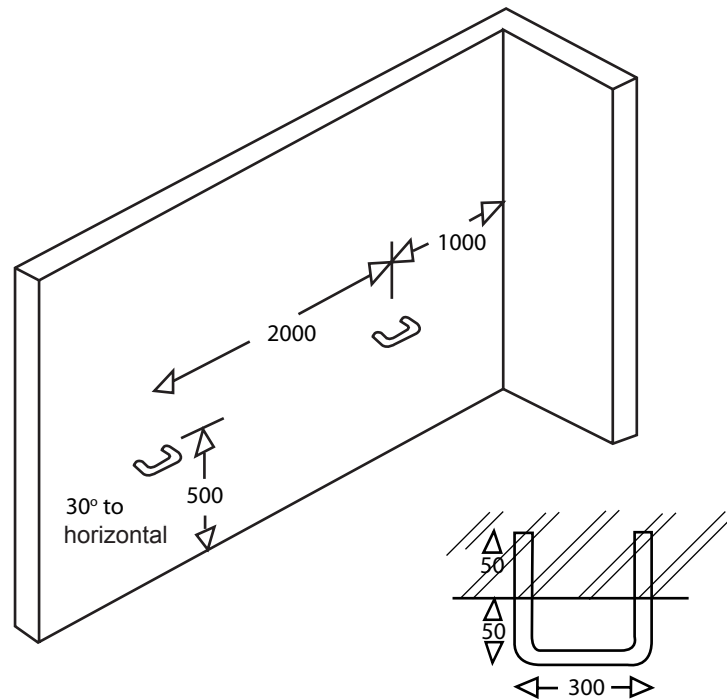

## Wall Bars

B12 Wall bars are simple, relatively inexpensive and may be more appropriate than Sheffield stands in areas where pavement widths are restricted. Refer to Figure 2. They may also be less environmentally intrusive than Sheffield stands in certain circumstances. The disadvantage with wall loops is that an excessively long chain is required to secure both the cycle wheels and the frame. Therefore, in the majority of circumstances wall bars are likely to only offer a limited level of security. Bars should be installed at an angle of 30°, should be 500mm from the ground at their lowest point, project no more than 50mm from the wall, and be a minimum of 2,000mm apart.

**Figure 3: Typical Cycle Locker**

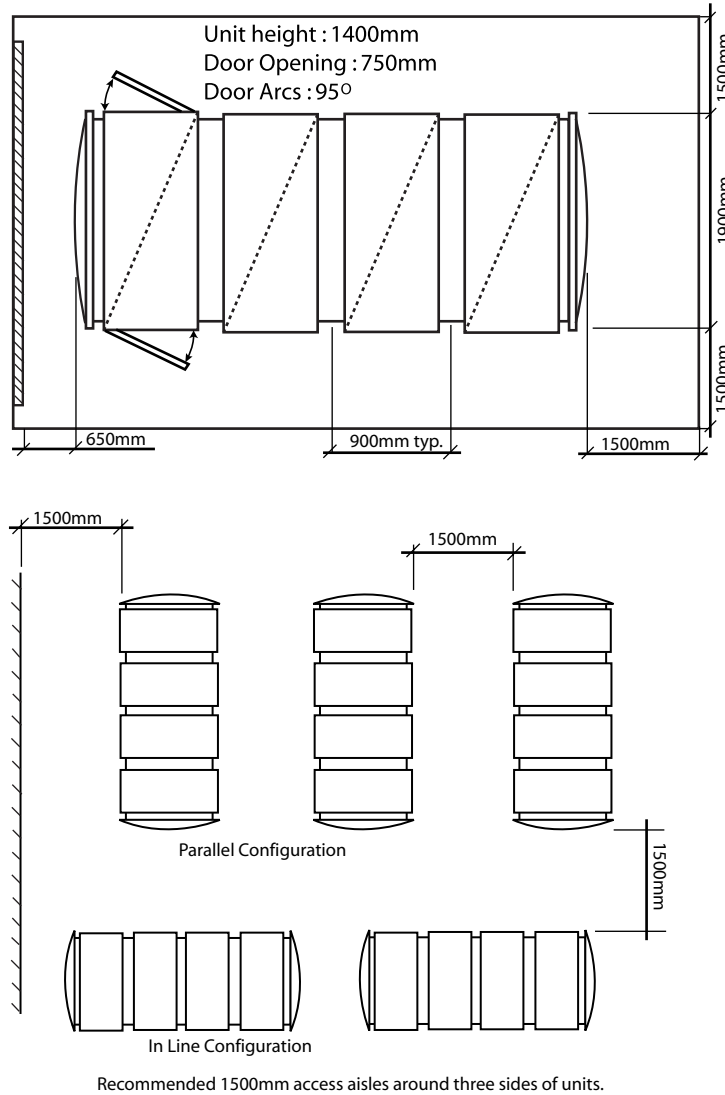

## Cycle Lockers

B13 When provided in conjunction with surveillance, cycle lockers offer a secure parking facility which allows accessories to be stored and provides weather protection (Figure 3). Lockers may be operated by coin or token, or be secured by cycle lock. Credit cards or 'smart' cards may also be used. At public transport interchanges a system of reserving lockers on a weekly, monthly or annual season ticket basis may be appropriate. Lockers should be a minimum of 750mm wide, 1,900mm long and 1,200mm high. A minimum space of 1,500mm should be provided in front of the locker door for ease of access. The main disadvantages with cycle lockers are that they are likely to be more expensive than Sheffield stands and may be visually intrusive within environmentally sensitive areas.

**Figure 4: Typical Cycle Store Layout**

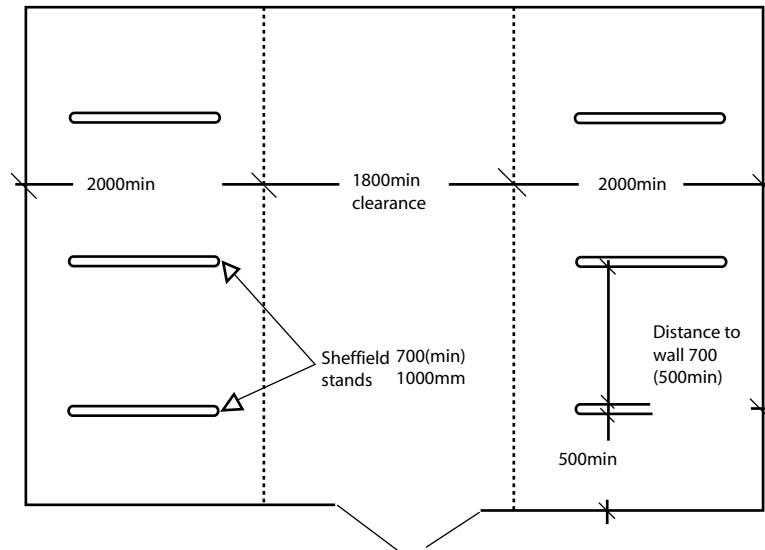

## Cycle Stores

B14 Cycle stores may be used in lieu of lockers where space permits. They can either be under continuous supervision or have a shared key arrangement, where each cyclist has a key to the outer door. Sheffield stands should be provided inside (Refer to Figure 4) in order that cycles may be individually secured. This type of arrangement is likely to be most appropriate at work places where users generally belong to the same group.

## Cycle Parking in Car Parks

B15 Supervised provision within car parks is a common form of continental commuter cycle parking. It has the benefit of offering increased security but without the additional cost of installing lockers or stores and may make efficient use of areas within the car park that may not otherwise be used, provided that the space is clearly visible.

## Cycle Parking Time Periods

B16 Cycle parking is generally required for 3 time periods:

- (a) Short Term < 2 hours;
- (b) Medium Term 2 - 12 Hours;
- (c) Long Term > 12 Hours.

### *Short to Medium Term Parking*

B17 Short to medium term parking facilities are generally used at:

- Public Transport Interchanges (Railway Stations, Light Rail Stations, Guided Bus Stations, Coach Stations, Major Bus Stops);
- Public Buildings (Central Government, Local Government, Health Facilities);
- Workplaces (Public, Private and Voluntary Organisations);
- Education Facilities (Primary, Secondary and Further Education);
- Shops and Shopping Centres;
- Parks and Leisure Facilities; and
- Places of Entertainment.

### *Medium to Long Term Parking*

B18 Medium to long term parking facilities are generally required at:

- Major transport Interchanges (Railway Stations, Coach Stations, Airports, Ferry Ports);
- Student Halls of Residence;
- Private Residences;
- Hotels and Hostels; and
- Camping and Holiday Sites.

B19 In addition to the requirements for short-medium stay parking, designs should aim to provide:-

- A higher level of security;
- Weather protection; and
- Storage areas.

B20 Cycle lockers, cycle stores (compounds) or supervised areas within car parks are likely to be more appropriate than unsupervised Sheffield stands as they provide increased security and storage facilities. Where necessary, location of Sheffield stands near to luggage lockers may be used.